



# Information Assurance Guidance 2012

Jeff Nieves  
IA Guidance Objective Lead  
March 2008

**This Briefing is Unclassified//For Official Use Only**



# IA Guidance Definition



IA Guidance is a product that provides educational or informative instruction intended to secure components, systems, operations, and personnel. Distinct from Security Engineering, IA Guidance products are intended for wide-spread application across a large and diverse group of consumers, as opposed to point solutions for specific clients.



# IA Operations 2012

## Information Assurance Guidance

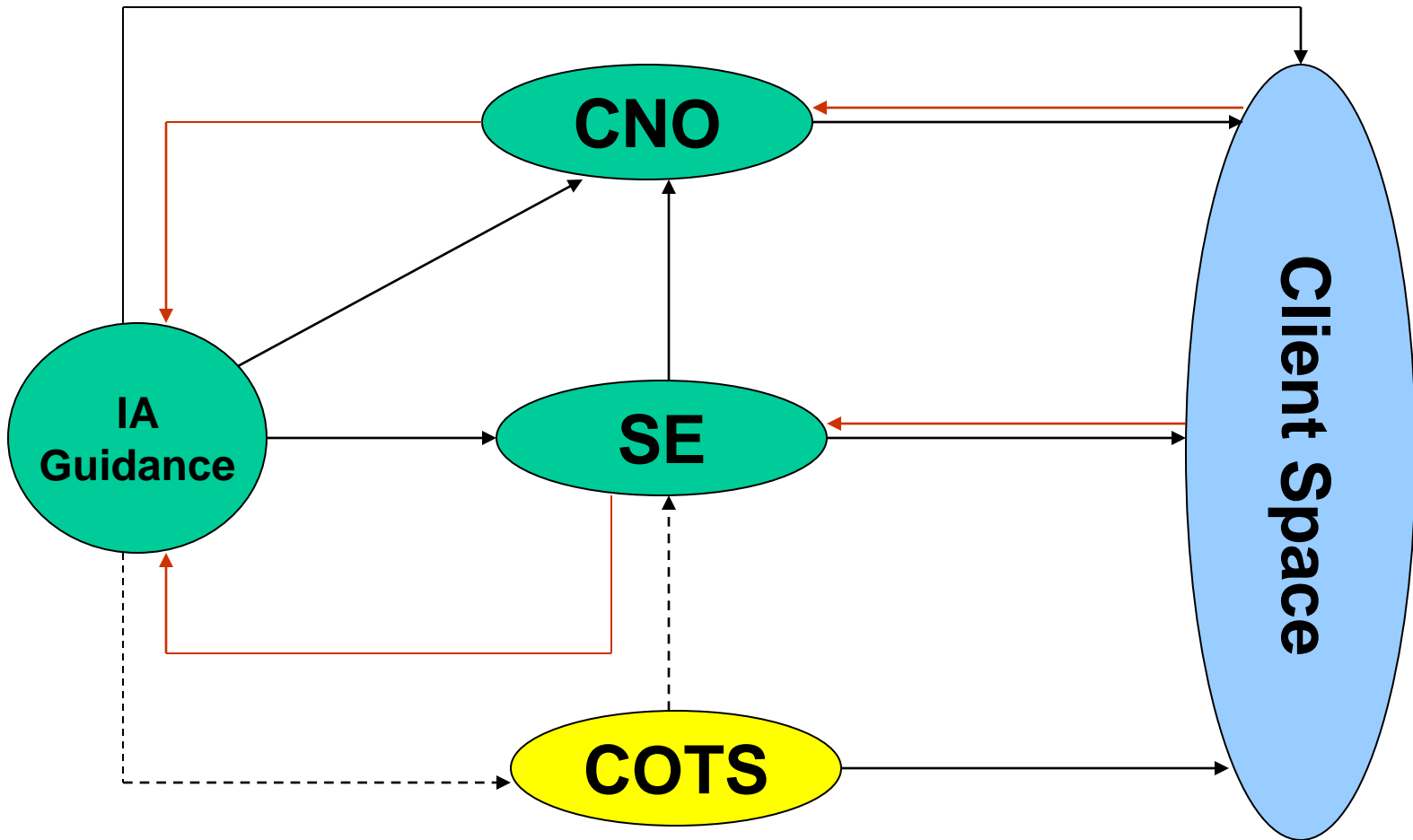



# IA Guidance Feedback



# Guidance consistency

- Published
- Endorsed
- Official

- Adhoc
- Unofficial
- SEAMs, CAs, SEs



# Guidance Services



System Life Cycle

Maintenance

Training

Retirement

IA Guidance Development

Operation

Requirements

Design

Implementation

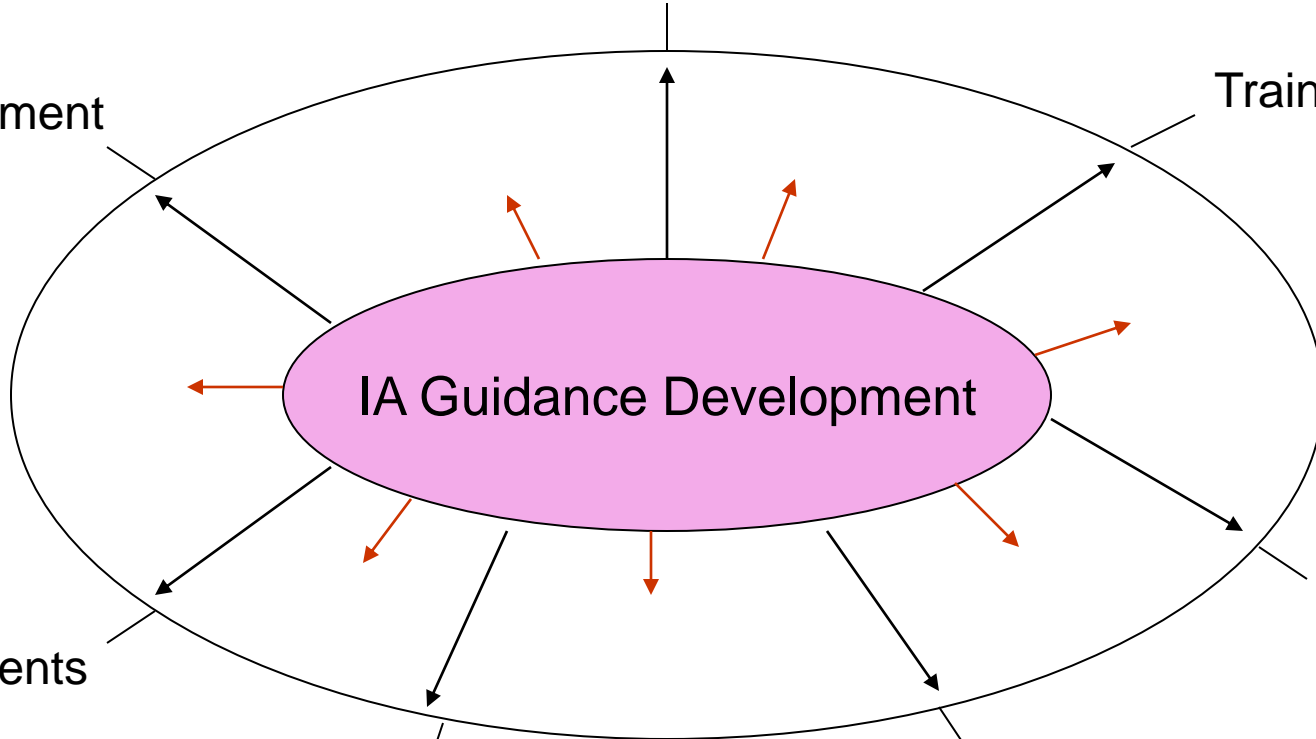



# IA Guidance 18 Month Roadmap



## Conduct Gap Analysis

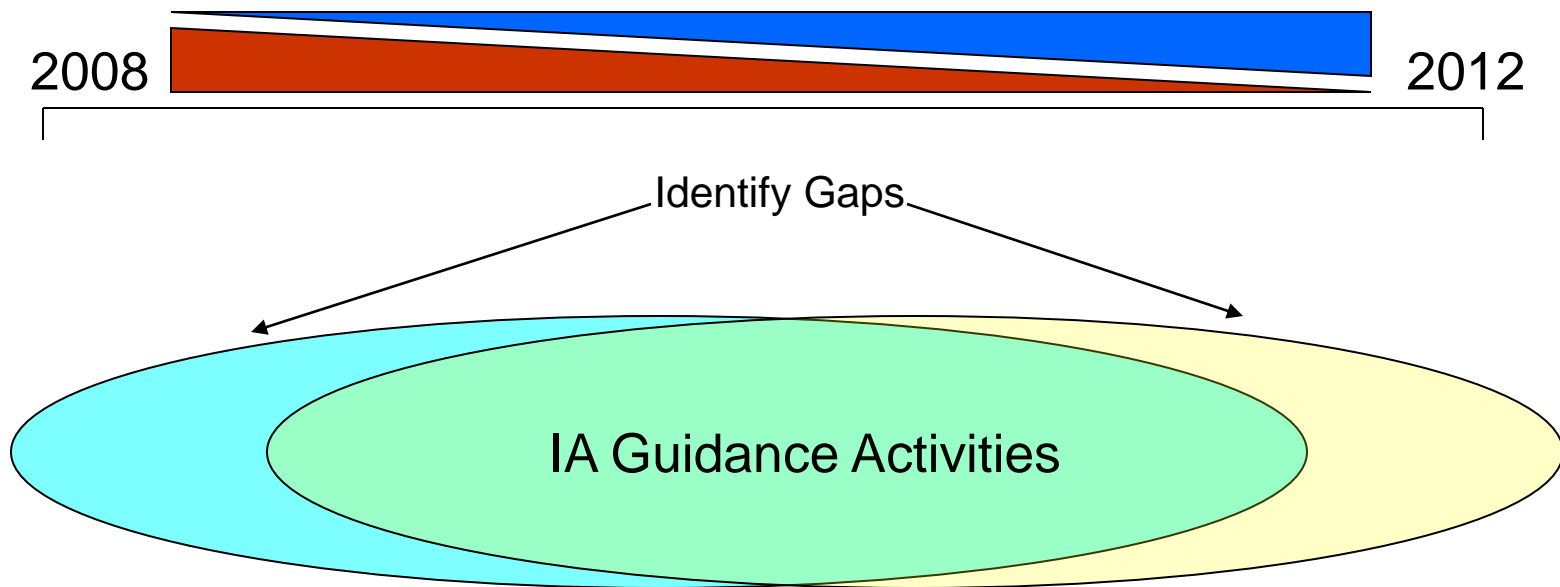

Guidance should be focused towards:

Enabling SE and ICNO  
Tactical Requirements  
Technology Forecasting

- COTS Technology
- GOTS Technology

# IA Guidance 18 Month Roadmap



## Guidance Initiatives

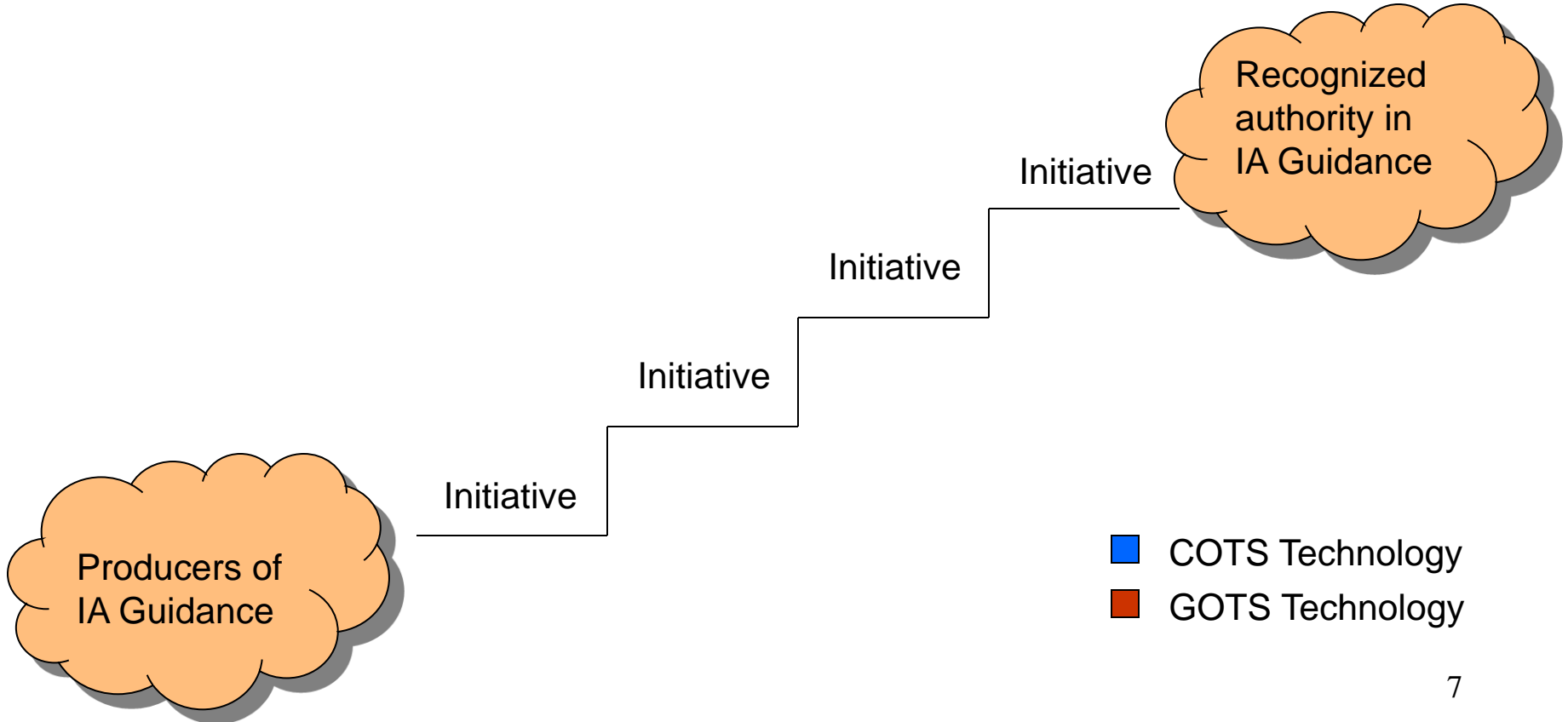
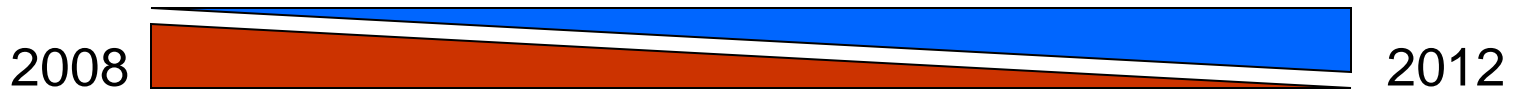

- COTS Technology
- GOTS Technology

# IA Guidance 18 Month Roadmap



## Community/Partner Engagement

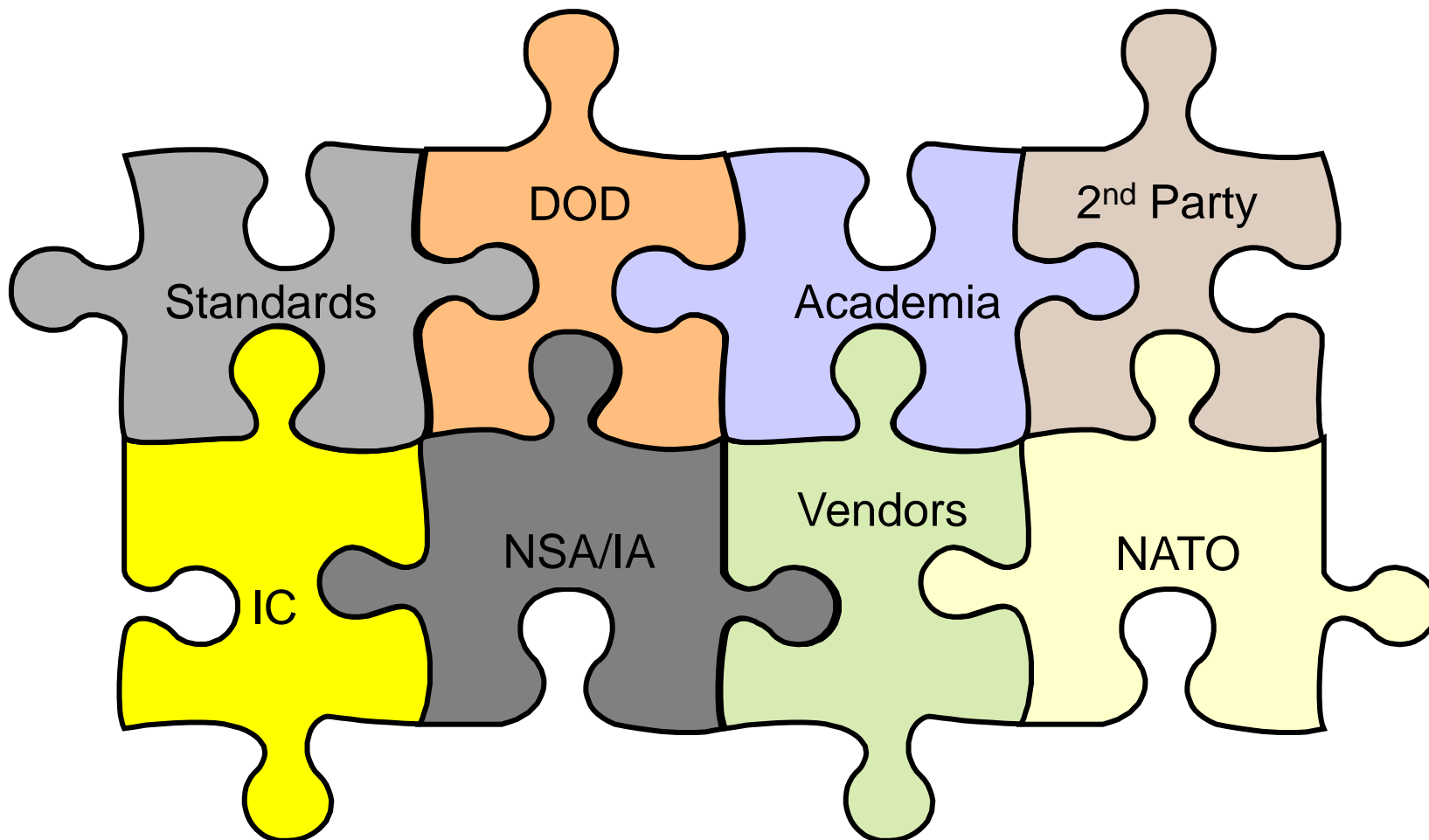





# (U) COTS Strategy Update



# (U) COTS Strategy Goal



(U) Increase our clients' ability to leverage commercial products & services in their national security operational environments



# (U) COTS Strategy Cycle



(U)

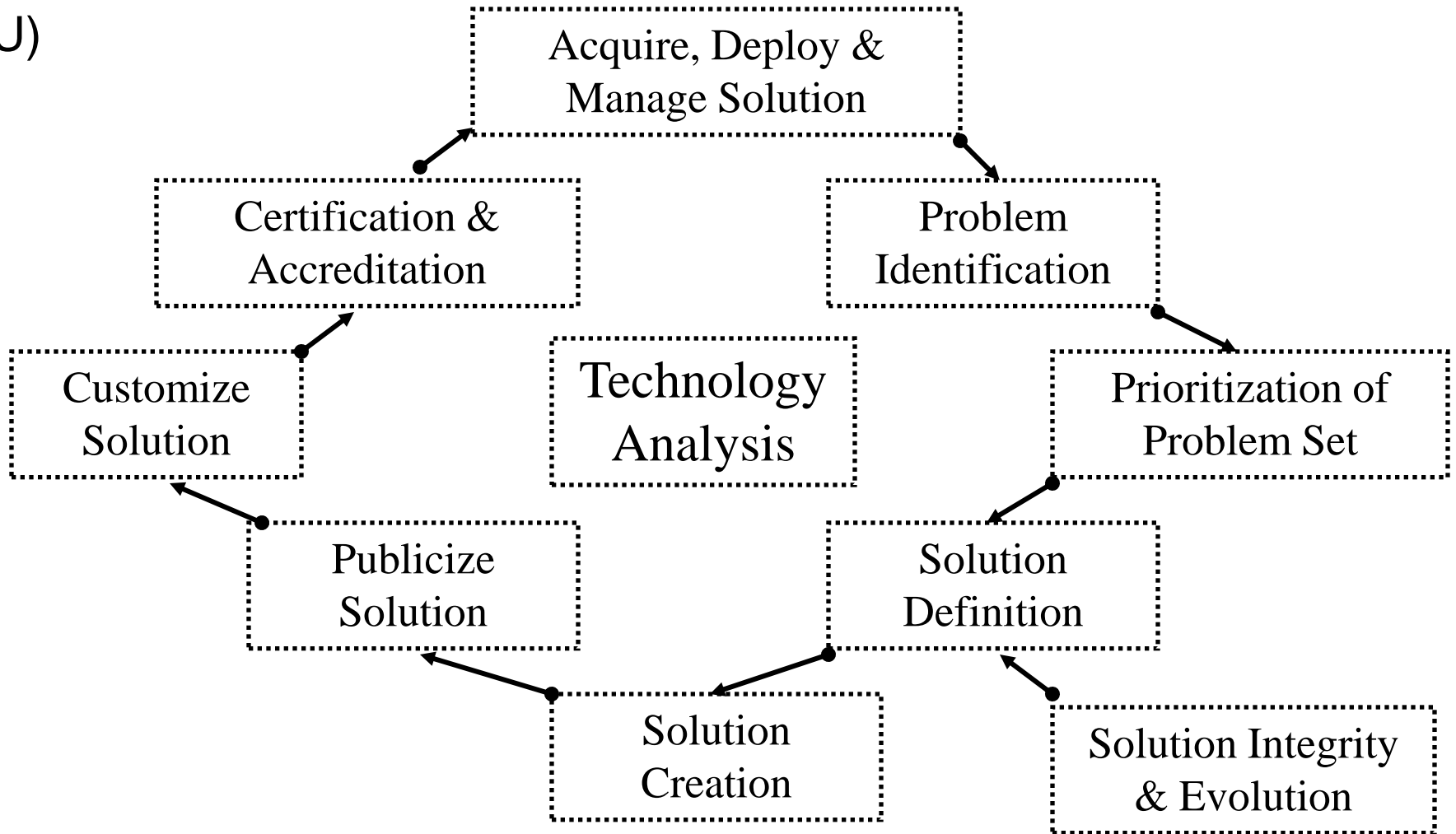



# (U) COTS Strategy Take-Aways



- (U) Radical departure from validating product claims to authorizing system oriented solutions – CULTURE CHANGE
- (U//FOUO) Open and unclassified activities supporting wide participation from industry, government and foreign partners
- (U) Vendors allowed to declare they meet the requirements
- (U) Evidence provided directly supportive of system engineering and system certification & accreditation
- (U) Opportunity to leverage customer test environments as part of the community effort.
- (U//FOUO) Conducting three pilots (secret laptop, wireless infrastructure in a protected facility, OS) to create real operational solution along with filling in details of process and model



# (U) Highlights of COTS Strategy Proposal



- (U//FOUO) Minor modifications required to NSTISSP#11 and other policies
- (U//FOUO) Problems vetted amongst community
- (U//FOUO) Solution specs authorized by NSA as national manager and issued as CNSS instructions
- (U//FOUO) Partner with NIST to leverage by reference NIST FIPS, Special Pubs
- (U//FOUO) Identify multi-prong approach to testing and component certification
- (U//FOUO) Tracking ODNI/DoD C&A revitalization
- (U//FOUO) NSA reserves right to evaluate



# (U) COTS Strategy Socialization



- (U//FOUO) Discussions with numerous partners/customers:
  - STRATCOM, SOCOM, EUCOM, NORTHCOM, State, Army, NIST, GSA, FBI, CSE, CESG, DSD & Customer Day
- (U//FOUO) Discussions with numerous vendors
- (U//FOUO) Continually met with IAD leadership to discuss topics and vet the concepts
- (U//FOUO) Held several IAD Town Meetings to solicit feedback from workforce



# (U) Next Steps COTS Secretariat



- (U//FOUO) COTS Secretariat:
  - Establish COTS Secretariat
  - Issue NSA policy defining COTS Strategy process and organizational roles and responsibilities
  - Develop detailed workflow for the rest of COTS Secretariat activities
  - Establish infrastructure required to collaborate with community



# (U) Next Steps Community Engagement



(U//FOUO) Engage with:

- CNSS
- NIST
- GSA
- 2<sup>nd</sup> Parties
- ODNI





# (U) Next Steps Pilots and Future Initiatives



## (U) COTS Initiatives

- Complete the pilots
  - Publish specifications
  - Interact with vendors to encourage participation
  - Continue involvement with customers
- Adjust details of solution specs, evidence and agreements as necessary
- Identify the next problems sets
- Complete Implementation Plan



**THE DECISIVE ADVANTAGE**